

Top Fan Tray (for wall mount only)

- Expel heat from the roof of the wall box
- Easily install into the top of the enclosure
- Provide low noise and high airflow performance
- 2 fans (216 CFM)

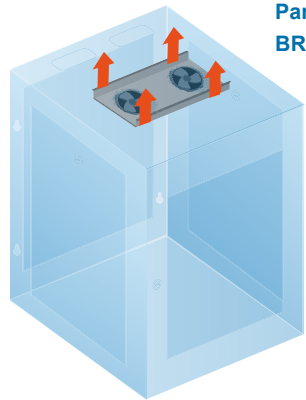

Part no. :
BR-F2

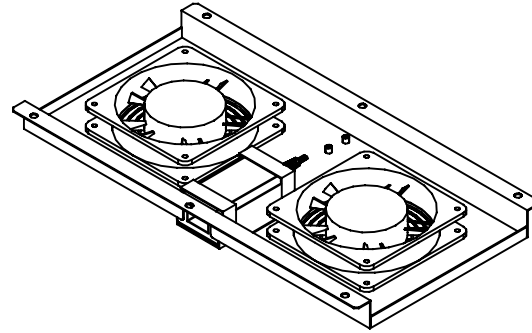

Top view:

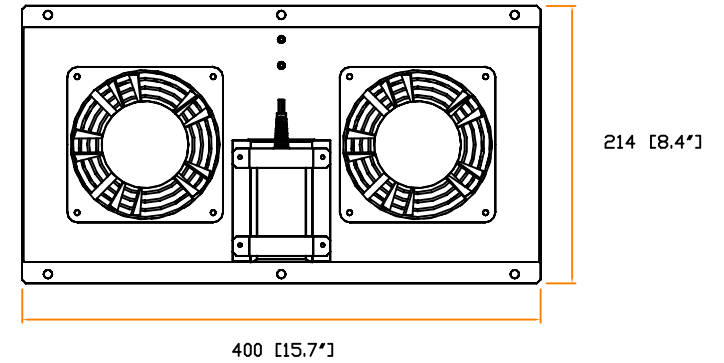

Rear view :

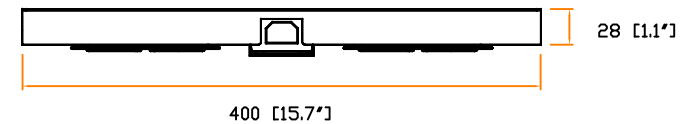

unit : mm / in.

The company reserves the right to modify product specifications without prior notice and assumes no responsibility for any error which may appear in this publication.

Copyright 2020 Austin Hughes Electronics Ltd. All rights reserved.



Design. Manufacturing. Global Services.

Description	: Wall mount top fan tray, 2 fans (216 CFM)
Screw	: M6 nut x 6
Fan size	: 120 (W) x 120 (H) x 25 (D) mm
Material	: Steel
Coating	: Powder
Color	: Grey white (RAL-9002)
Dimension	: 400 (W) x 214 (H) x 36 (D) mm / 15.7 (W) x 8.4 (H) x 1.4 (D) in.
Gross weight	: 1.33 kg / 2.93 lb
Environmental	: RoHS3 & REACH compliant by SGS